



# Lincoln Fit Window Installation Instructions

## POCKET INSERT REPLACEMENT PRODUCT

The Lincoln Fit window is available in either Double Hung or Casement fixed and operating units. The installation procedures are identical for both unit types except where noted.

### Parts included for Double Hung Installation:

- Jamb Jacks (2) – Operating Units.
- Jambliner Hole Plugs (2) - Operating Units
- #6 X 2-1/2" Screws (4) – Operating Units
- #8 X 3" Screws (10) – Fixed Units
- Sill Frame Expander

### Parts included for Casement Installation:

- #8 X 3" Screws (9) – Operating and Fixed Units
- Sill Frame Expander

### Before you begin:

- LINCOLN FIT window operating and fixed units may be installed from the interior or exterior.
- The condition of the existing frame must be inspected. Check the existing frame for rot or deterioration. Repair or replace where necessary. Confirm that the existing frame opening is reasonably close to being plumb, level and square. This will ensure a proper fit of the LINCOLN FIT unit.
- Check the jamb pocket depth. If the depth of pocket is less than 3-5/16" or greater than 3-3/8", modification of the pocket may be necessary.
- LINCOLN FIT windows are designed to fit openings with a sill angle between 8° and 14°. If the sill angle is greater than 14° the sill weatherstrip may not make contact with the sill. Alternate weather-stripping and/or additional sealant (by others) may be required. Sill angles closer to 8° may require the sill weatherstrip to be removed and a backer rod and sealant used at the sill area. Sill angles less than 8° will not work with this unit without field modification.

## EXTERIOR INSTALLATION

### Removing the Old Sash and Preparing the Opening

1. Remove any exterior screens or storm windows.
2. Remove side and head parting stops and then remove sash.
3. Remove any weights, pulleys, balance cords, jambliners or any other related hardware from the side jambs, head jambs and sill.
4. Check the existing frame for rot or deterioration. Repair or replace where necessary.
5. Using a reciprocating saw, cut the exterior head and side stops so they are flush with the exterior casing and side/head jambs. See Figure 1.

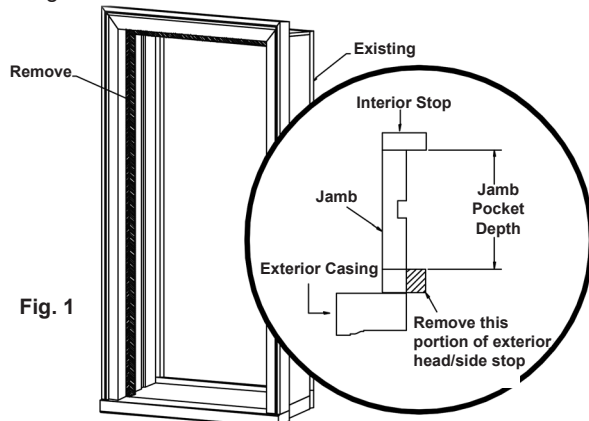

Fig. 1

6. Apply a 1/4" – 3/8" bead of sealant to the backside of the interior stops around the entire perimeter. Apply a secondary bead of sealant to the sill area at the sill to side jamb joints. See Figure 2.

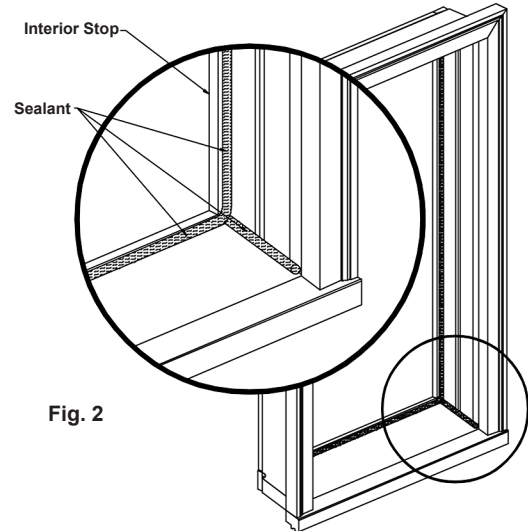

Fig. 2

## INTERIOR INSTALLATION

### Removing the Old Sash and Preparing the Opening

1. Remove all interior stops/casing with a pry bar or stiff putty knife. **IMPORTANT:** Do not break or damage parts as they may be reused.
2. Remove side and head parting stops and then remove sash.
3. Remove any weights, pulleys, balance cords, jambliners or any other related hardware from the side jambs, head jambs and sill.
4. Check the existing frame for rot or deterioration. Repair or replace where necessary.
5. Apply a 1/4" – 3/8" bead of sealant to the backside of the exterior side and head stops. Apply a secondary bead of sealant to the sill area at the sill to side jamb joints. See Figure 3.

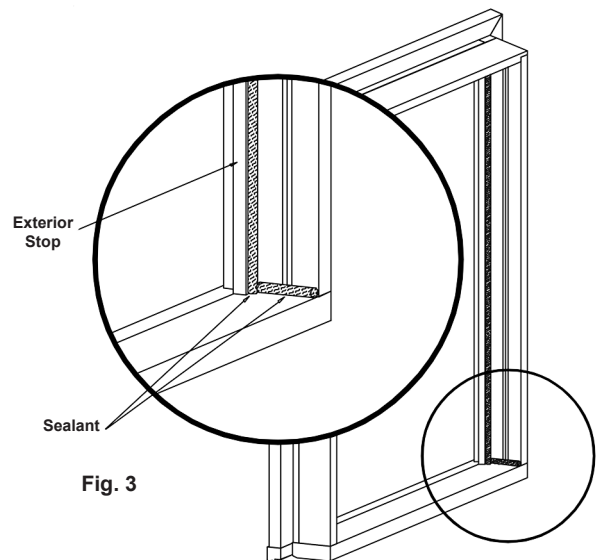
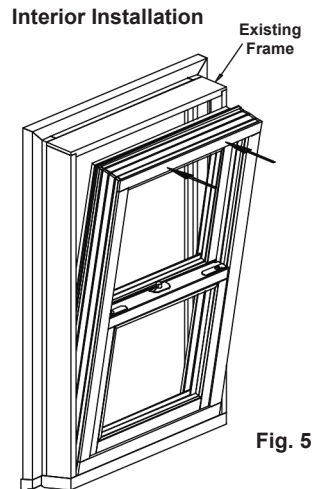
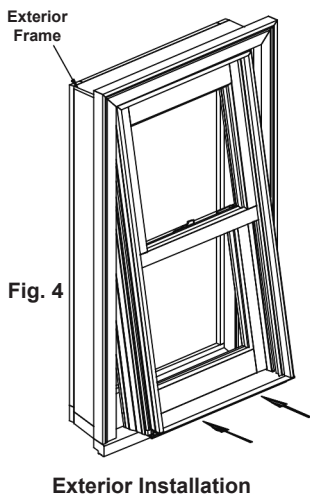

Fig. 3

## INSTALLING THE LINCOLN FIT WINDOW

**Note:** For ease of installation, it is recommended to have the assistance of another individual when installing this product.

1. Remove all shipping skids from the underside of the sill and any corner braces. **Note:** Leave banding on frame, until unit is square in the opening and properly shimmed.
2. **Exterior Installation:** Center unit in opening and press it firmly against interior stops. See Figure 4.
3. **Interior Installation:** Center unit in opening and press it firmly against exterior stops. See Figure 5.



*Double Hung shown in illustrations, Casement installation is similar.*

6. Making sure that the unit is square, level and plumb, drive the four #6 x 2-1/2" screws provided through the predrilled holes at the top and bottom corners. Do not overtighten screws.
7. Recheck squareness of unit. Adjust screws as necessary to obtain squareness of frame. Once squareness of frame is verified, apply shims between the existing frame and the side jambs of insert window at the mid point of the side jambs. Do not over-shim.
8. On the exterior, below the top check rail, is a predrilled hole in the jambliner for each jamb jack. Using this hole as a guide, drill a 1/8" pilot hole into the existing window frame. Insert jamb jacks into each hole using an S3 square bit driver and drive until the jamb jack bottoms out. See Figure 8.

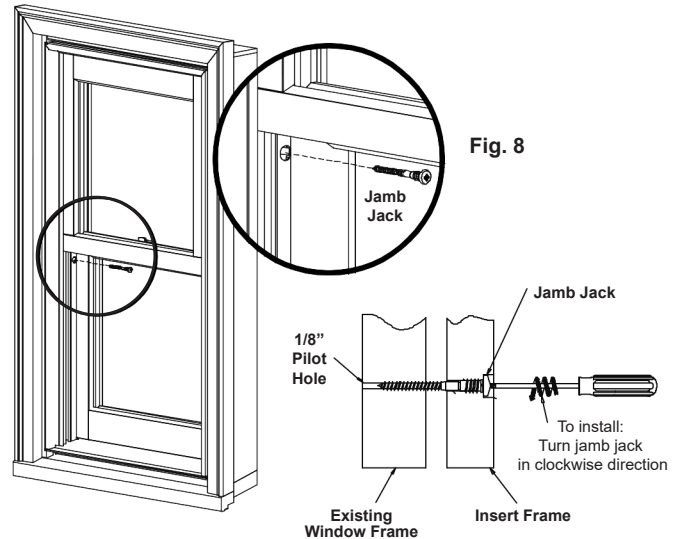

9. Measure the width of the unit at the head, sill and check rail. These measurements should be equal. If not, adjust the jamb jacks to obtain an even reveal between sash and frame and for proper sash operation. Using an S3 square bit driver, turn the jamb jack clockwise to move the jambs away from the sash and counterclockwise to move the jambs toward the sash. Adjust jamb jacks until the width measurements at the head, sill and check rail are equal. Insert plastic hole plugs provided into the jambliner at the jamb jack location. Adjust shims at checkrail as necessary. See Figure 9.

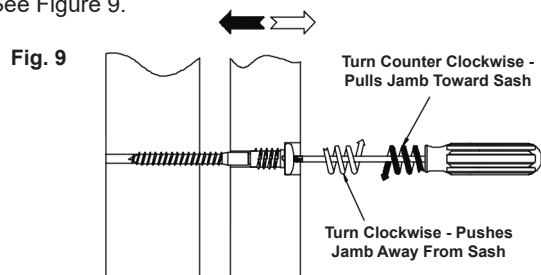

### Jamb Jack Adjustment

10. Shim head jamb if necessary.
11. Cut off shims flush with exterior or interior of frame depending on installation technique. Fill the space between the insert window frame and existing window frame with insulation. **Caution:** If using expanding foam insulation, do not overfill. This will cause the head/sidejambs/sill to bow and affect operation of the unit.

**Mulled Units:** If installing mulled Lincoln Fit units into an opening, drive 2-1/2" finish nails through the head jamb and into the existing frame. Space nails 10-12" apart.

**Go to page 4 to finish installation**

## FASTENING DOUBLE HUNG UNIT IN OPENING

**Note:** For ease of installation, it is recommended to have the assistance of another individual when installing this product.

1. If necessary, shim under sill to level the unit.
2. Place shims in all 4 corners between the existing frame and the pocket insert frame and adjust as necessary until the frame is square, level and plumb in the opening.
3. Raise the bottom sash and lower the top sash.
4. At the bottom of the interior sash track, approximately 2-3" above the sill, there is a 1/8" pilot hole through the back of the jambliner pocket in each side jamb. Using this hole as a guide drill a 1/8" hole into the existing frame. See Fig. 6.
5. At the top of the exterior sash track, approximately 2-3" below the head jamb, there is a 1/8" pilot hole through the back of the jambliner pocket in each side jamb. Using this hole as a guide drill a 1/8" hole into the existing frame. See Figure 7.

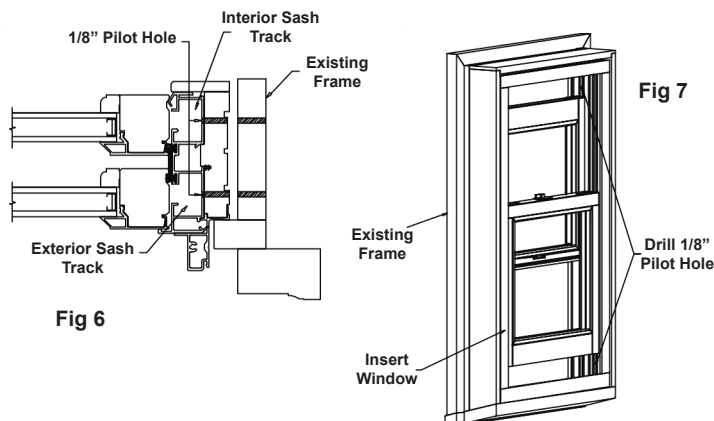

## FASTENING A DH STUDIO UNIT IN OPENING

**Note:** For ease of installation, it is recommended to have the assistance of another individual when installing this product.

1. If necessary, shim under sill to level the unit.
2. Place shims in all 4 corners and adjust as necessary until the frame is square, level and plumb in the opening.
3. The stops in the side jambs are tacked in loosely. Remove side stops and drill 1/8" pilot hole through side jambs and into existing frame. A minimum of 3 holes per side must be drilled. One near the top and bottom corners and one in the middle of the side jamb. Drill more holes for taller units. See Figure 12.
4. Making sure that the unit is square, level and plumb, drive the #6 x 2-1/2" screws provided through the predrilled holes at the top and bottom corners. Do not overtighten screws.

Fig. 12

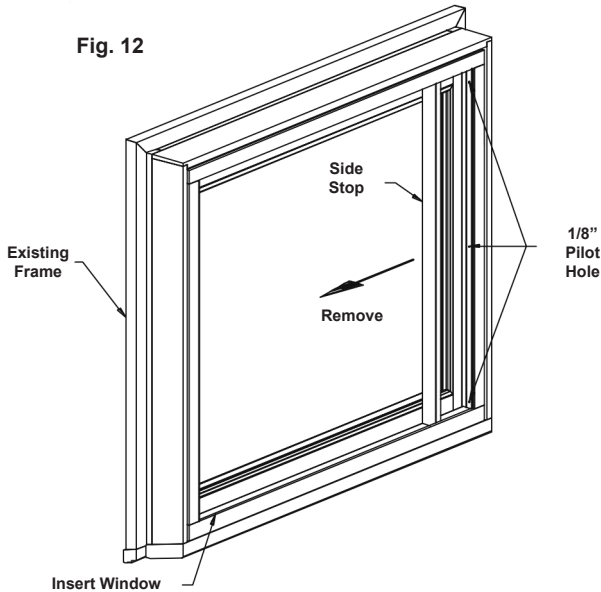

5. Recheck squareness of unit. Adjust screws as necessary to obtain squareness of frame. Once squareness of frame is verified, apply shims between the existing frame and the side/head jambs of insert window. Do not over-shim. Drive remaining #8 x 3" screws through predrilled holes. Re-apply side stops and fasten with finish nails. **Note:** Units that are larger in width may require additional fastening. To do this, drive 2-1/2" finish nails through the head jamb and into the existing frame. Space nails 10-12" apart.
6. Cut off shims flush with exterior or interior of frame depending on installation technique. Fill the space between the insert window frame and existing window frame with insulation. **Caution:** If using expanding foam insulation, do not overfill. This will cause the head/sidejamb/sill to bow.

**Mulled Units:** If installing mulled Lincoln Fit units into an opening, drive 2-1/2" finish nails through the head jamb and into the existing frame. Space nails 10-12" apart.

**Go to page 4 to finish installation**

**Note:** For ease of installation, it is recommended to have the assistance of another individual when installing this product.

1. If necessary, shim under sill to level the unit.
2. Place shims in all 4 corners between the existing frame and the pocket insert frame and adjust as necessary until the frame is square, level and plumb in the opening.
3. Carefully remove all interior Casement stops by pulling on the straps connecting them to the frame. Cut off the straps from the stops after removal.
4. Making sure that the unit is square, level and plumb, drive four #8 x 3" screws provided through the side jamb approximately 3" from the top and bottom corners. Do not overtighten screws. See Figures 10 & 11.
5. Recheck squareness of unit. Adjust screws as necessary to obtain squareness of frame. Once squareness of frame is verified, apply shims between the existing frame and the side jambs of insert window at the mid point of the side jambs. Do not over-shim.
6. Place the remaining two #8 x 3" screws into the mid-point of the the window on each side.

Screw Heads Must Be Flush With Jamb For Stop Clearance

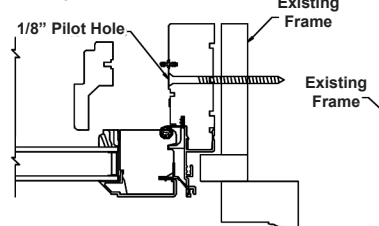

Fig 10

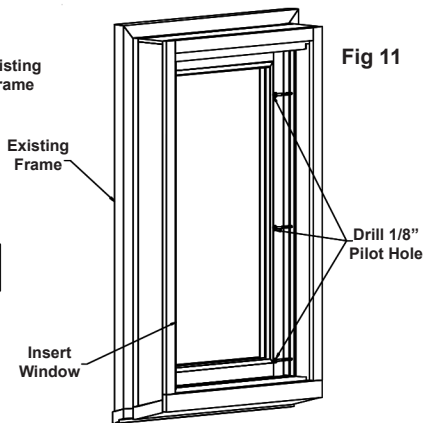

Fig 11

7. Re-apply the interior Casement stops, starting with the side stops.
8. Shim head jamb if necessary.
9. Cut off shims flush with exterior or interior of frame depending on installation technique. Fill the space between the insert window frame and existing window frame with insulation. **Caution:** If using expanding foam insulation, do not overfill. This will cause the head/sidejamb/sill to bow and affect operation of the unit.

**Mulled Units:** If installing mulled Lincoln Fit units into an opening, drive #8 x 3" screws through the head jamb and into the existing frame. Space screws 10-12" apart.

**Go to page 4 to finish installation**

## FASTENING CASEMENT STUDIO UNIT IN OPENING

**Note:** For ease of installation, it is recommended to have the assistance of another individual when installing this product.

1. Fastening is done identically to a standard Casement unit, see above instructions, with the addition of the following procedure.
2. Three #8 x 3" Screws need to be inserted through the head jamb, 3" from the top corners and at the midpoint of the window.

**Go to page 4 to finish installation**

## APPLYING BACKER ROD & SEALANT

### Exterior Installed Application

12. Apply a backer rod between insert frame and existing window frame at the head and sides. Place a bead of sealant around the perimeter of the frame to bridge the gap between the insert frame and existing window frame/casing. See Figures 13 & 14.

Fig. 13

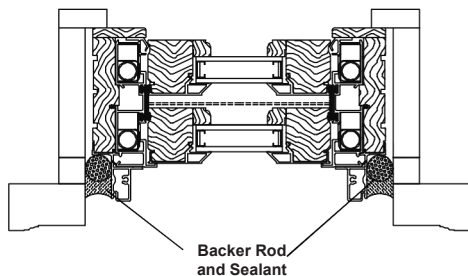

### Exterior Installed Application

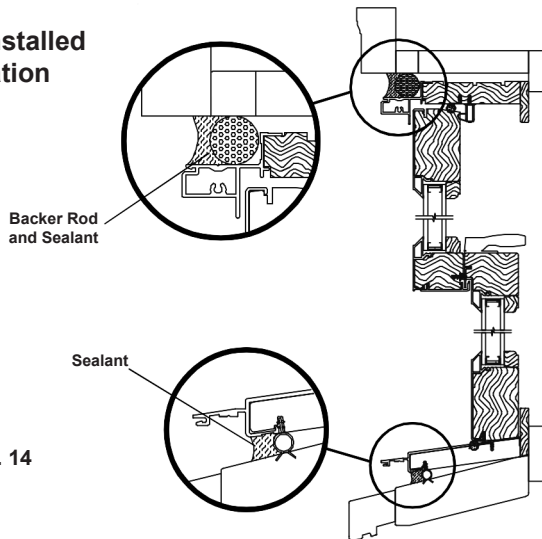

Fig. 14

*Double Hung shown in illustrations, Casement installation is similar.*

14. If applying frame expander, do so at this time. The frame expander may need to be cut to the proper width to bridge the gap between the insert frame and existing window frame/casing. Notches on the back of the frame clad expander are spaced 1/8" apart for cutting reference. Once the frame clad expander is installed, seal the joint between the frame clad expander and existing frame. See Figures 13 & 14.

**NOTE:** Frame expander is provided for sill only. Additional expanders can be ordered for sides & head.

### Interior Installed Application

13. Interior Installed Application: Re-apply interior stops and casing. If there is a gap between the stops/casing and insert frame, apply a small bead of clear sealant around the entire perimeter of the unit between the stops/casing and insert frame. If necessary, install a backer rod prior to sealant application.

Apply a bead of silicone between the insert window frame and the exterior stops. If necessary, install a backer rod prior to sealant application. See Figures 15 & 16.

Fig. 15

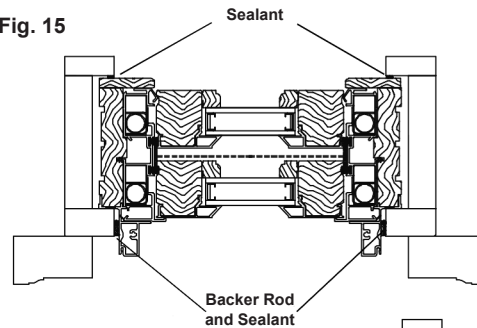

### Interior Installed Application

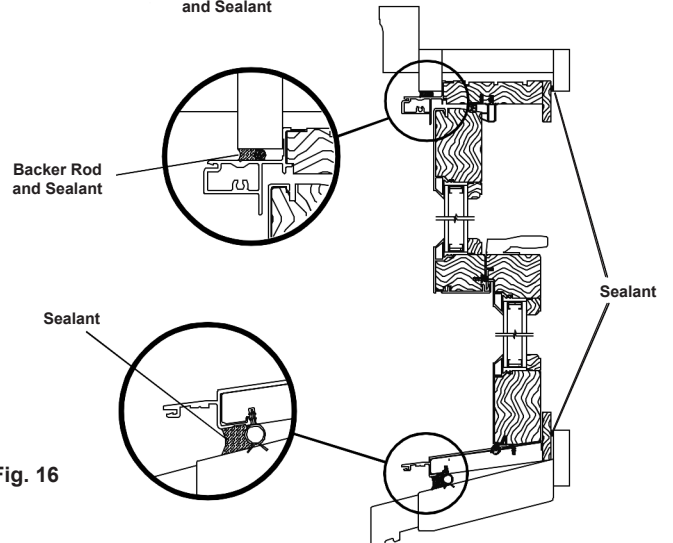

Fig. 16

*Double Hung shown in illustrations, Casement installation is similar.*

## APPLYING FRAME EXPANDER

14. If applying frame expander, do so at this time. The frame expander may need to be cut to the proper width to bridge the gap between the insert frame and existing window frame/casing. Notches on the back of the frame clad expander are spaced 1/8" apart for cutting reference. Once the frame clad expander is installed, seal the joint between the frame clad expander and existing frame. See Figure 17.

**NOTE:** Frame expander is provided for sill only. Additional expanders can be ordered for sides & head.

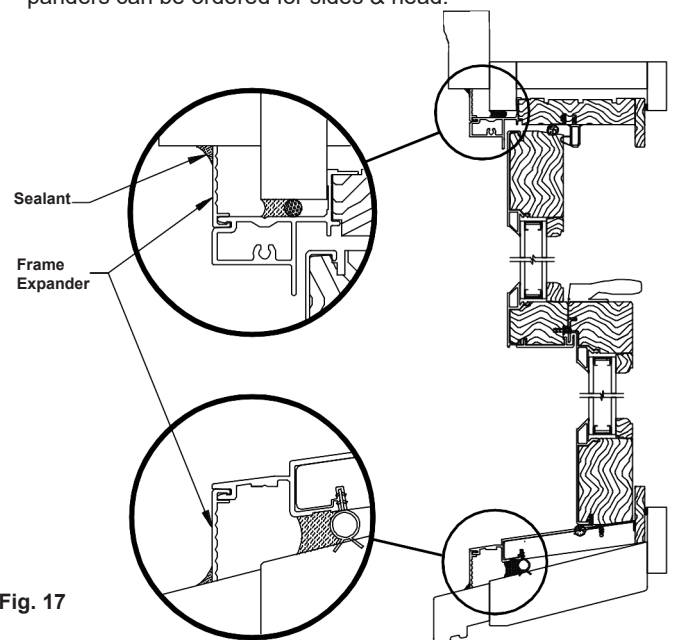

Fig. 17

*Double Hung shown in illustrations, Casement installation is similar.*